

Multiplelabs

Research Testing Training Applications & Beyond



Analytical[®]
Technologies Limited

LC-MS-MS: 3521

LIQUID CHROMATOGRAPH-TRIPLE QUADRUPOLE MASS SPECTROMETER



EPCC / PRODUCTS / APPLICATION / SOFTWARE / ACCESSORIES / CONSUMABLES / SERVICES

Analytical Technologies Limited

An ISO 9001 Certified Company

www.analyticalgroup.net

LC-MS/MS is a triple quadrupole tandem mass spectrometer with independent intellectual property rights developed by Analytical Technologies Limited, with the support of "national major scientific instrument and equipment development project", after years of research and development and investment and employing a series of innovative mass spectrometry technologies. At the core technology of three quadrupole tandem mass spectrometry, the key technologies high stability electrospray ion source, high efficiency solvent removal ion interface, triple quadrupole with high ion transmission efficiency, triple quadrupole mass analyzer, high-speed collision cell, and RF circuit drive have been resolved, and a new triple quadrupole tandem mass spectrometry product with superior performance has been built.

LC-MS/MS has excellent sensitivity and stability, outstanding scalability and best cost performance and is suitable for a wide range of application fields such as environmental testing, medical testing and food safety. The mass spectrometry workstation software independently developed for user needs, "Mass Pundit", includes professional mass spectrometry control and quantitative analysis software, combined with standard method library, automatic tuning, intelligent batch processing and customized report output functions, which greatly reduces the operation difficulty of mass spectrometry software system. At the same time, Mass Pundit also has thousands of compound standard libraries and rich application method libraries to meet the application needs of more mass spectrometry users.

Product Features

LC-MS/MS 3521 triple quadrupole mass spectrometry

Excellent performance and easy operation make it possible for LC-MS to enter more testing laboratories.

Unique design of biorthogonal ion source and double 3Q ion optical LC-MS/MS has excellent ionic yield and resistance to matrix with adopting E spray biorthogonal electrospray ion source technology LC-MS/MS 3521 adopts unique triple quadrupole ion guidance technology and triple quadrupole mass analyzer technology to ensure the analytical performance and long-term stability.

Excellent sensitivity

The product adopts the step scan, a kind of newly designed ion transmission technology, which effectively improves the ion transmission efficiency.

The innovative technology of axial acceleration collision cell improves the collision efficiency greatly.

The patented technology of pulse counting detection can detect ion signals without loss and filter noise interference effectively.

Excellent stability

Ion source and ion interface with efficient desolvation to increase system tolerance.

The patented closed-loop adaptive adjustment technology of dual RF power supply improves the stability of quadrupole RF power supply

The patented anti temperature and humidity alternating technology is suitable for a wider range of temperature and humidity applications.

Mass Pandit mass spectrometry workstation

The control software and analysis software of completely new Mass Pandit mass spectrometry are simple to operate.

The function of one-click automatic tuning and quality calibration reduces the complexity of instrument control and the threshold of instrument use. Mass spectrometry analysis software and report template can be customized according to different application fields and different users to meet the use needs of various application fields.

Innovative triple quadrupole mass spectrometry Ion interface Gas circuit with special heating, independent temperature control for blowback gas Blowback gas designed to further improve the desolvation High purity nitrogen back blowing to eliminate interference

Biorthogonal e-spray ion source

Powerful and scalable ESI ion source.

Orthogonal ion path with 90 degree deflection to reduce neutral particles entering the mass spectrum and reduce noise.

Orthogonal symmetrical two-way desolvation gas based on flow field simulation to maximize solvent removal

Reliable multistage vacuum system

Multi stage vacuum system based on molecular pump and front stage pump

Step transition of vacuum to reduce sudden change of air pressure and ion loss

Perfect instrument control system

All gas circuits, voltages and heating have interlocking control to ensure equipment safety.

The vacuum system is independently controlled and has perfect self-protection. It can ensure the normal operation of the system without software.

All gas circuits are controlled by MFC to control all parameters accurately

Step Scan ion transport

3Q quadrupole transmission system design is adopted to maximize transmission efficiency.

Axially accelerated Q-funnel ion acquisition to improve ion transmission efficiency

Unique Q-lens, connected with ion interface perfectly

Q- guide, improved quadrupole transmission channel to ensure all ions efficient transmission.

TQ quality analyzer

Pure molybdenum quadrupole mass analyzer with gold plating for best thermal stability.

Ultra stable frequency modulation quadrupole RF power supply, with excellent resistance to temperature and humidity changes, ensuring good stability under ordinary laboratory conditions.

TQ quality analyzer

The patented second generation Hexapole Collision reaction tank

The design of axial acceleration enables ions to pass through the collision cell quickly, taking into account collision efficiency and transmission efficiency

The patented distributed collision gas diffusion mode improves collision efficiency and sensitivity greatly.

Pulse counting detector

Proprietary channel electronic multiplier with deflection

The patented pulse count detection with higher signal response and lower noise

Robust and efficient ion optics

The innovative double 3Q ion optical system has high ion transmission efficiency, good matrix tolerance, good balance sensitivity and stability, and has excellent application performance.

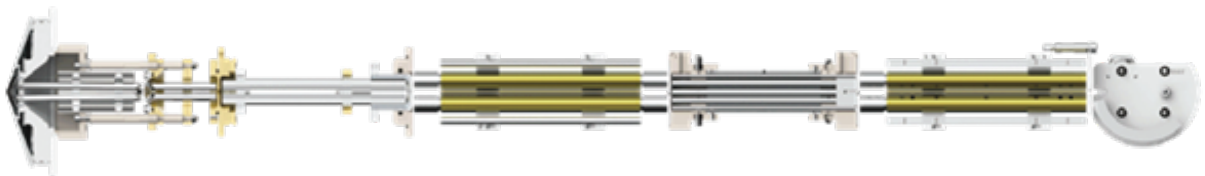

Step Scan 3Q ion transport system

Integrated packaging, easy to disassemble and cleaning

Three groups of quadrupoles form a unique 3Q ion transmission channel with large ion path and high ion transmission efficiency

Quadrupole design and step scanning can reduce the interference of low quality ions greatly

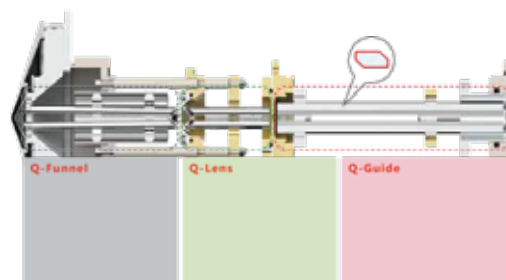

Tandem QQQ quality analyze

Adopt design of tandem Quadrupole mass analyzer and Six-pole collision cell

The stable dual mass analyzer can carry out various mass analysis scans and is suitable for various mass spectrometry research work

Efficient collision cell for maximum ion transport

Including full scan, SIM, SRM, product ion scan, precursor ion scan, neutral loss scan and MRM.

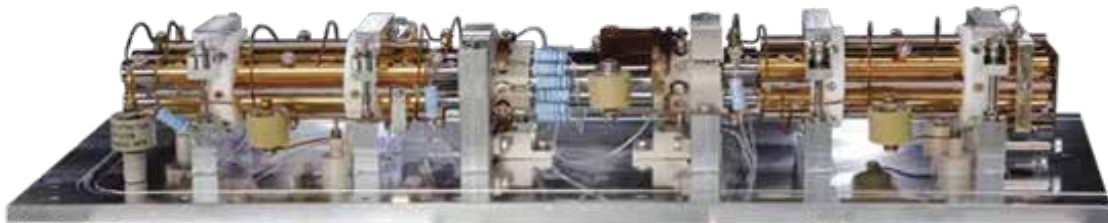

Self-developed pure molybdenum quadrupole mass analyzer

Pure molybdenum quadrupole with the best material stability to ensure the stability of the quality axis

The surface of quadrupole is plated with gold and completely inert to eliminate organic deposition

The patented closed-loop adaptive adjustment technology of dual RF power supply to improve the stability of quadrupole RF

The patented temperature and humidity alternating resistance technology can , (20 ~ 80)% R.H

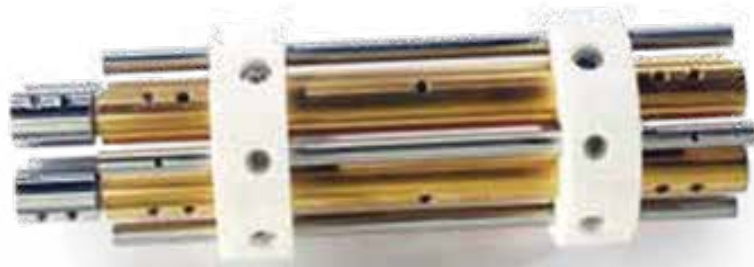

Axial acceleration collision cell

Eliminate crosstalk between ion pairs and no memory effect. Matching ultra-fast liquid chromatography for high-throughput analysis of nearly 100 compounds at the same time

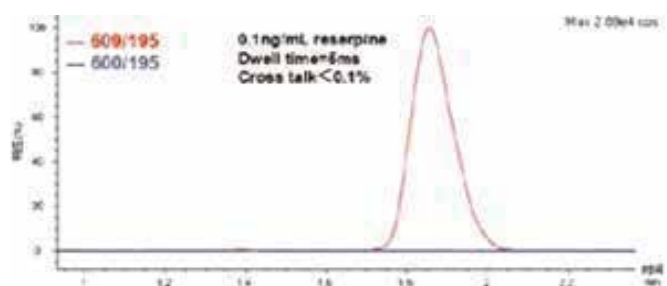
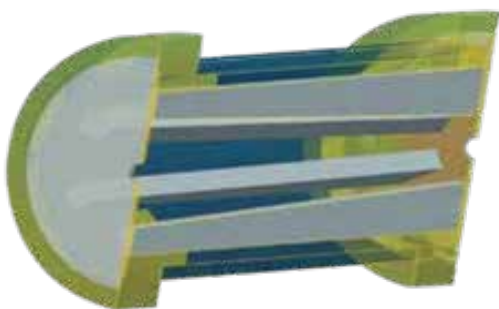

Collision cell cross-contamination experiment results: the experiment uses two channels: the true channel 609-195 and the false channel 600-195, the dwell time is 5ms, and the ratio of the peak area of the false channel to the true channel to that of the true channel is less than 0.1%

Advanced quadrupole RF power supply technology

The patented closed-loop adaptive adjustment technology of dual RF power supply is adopted to improve the stability of quadrupole RF voltage, ensure the symmetry of RF power supply, and improve the accuracy of ion screening and ion transmission greatly.

Completely new temperature and humidity resistance technology is adopted to improve the environmental adaptability of quadrupole driving power supply, and the mass spectrum peaks are very stable in the full temperature and humidity range

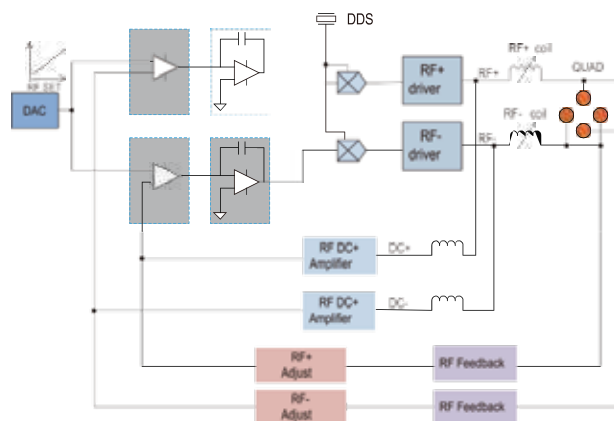

Excellent stability serves the applications of LC-MS/MS

Orthogonal transmission of E-Spray electrospray ion source

By orthogonal vertical spray ESI ion source with 90 degree deflation reduces direct injection neutral particle pollution, reducing noise while prolonging maintenance cycle greatly.

Coaxial atomized forms a powerful and stable ion source, which is suitable for stable injection at various flow rates of 5ul / min ~ 2ml / min.

the ion source is three-dimensional adjustable, which is suitable for users to optimize the ion collection position according to the actual situation.



Orthogonal desolvation gas, aerodynamic and efficient desolvation

Based on the distribution of aerodynamics and thermodynamics, the spatial position of desolvation gas is optimized, and the orthogonal and symmetrical arrangement has the best desolvation effect.

Independent temperature control of two-way desolvation gas, and the maximum desolvation gas temperature can reach 700

The temperature and flow of desolvation gas can be automatically optimized and switched, and can be flexibly adjusted according to the application to achieve the best effect of desolvation

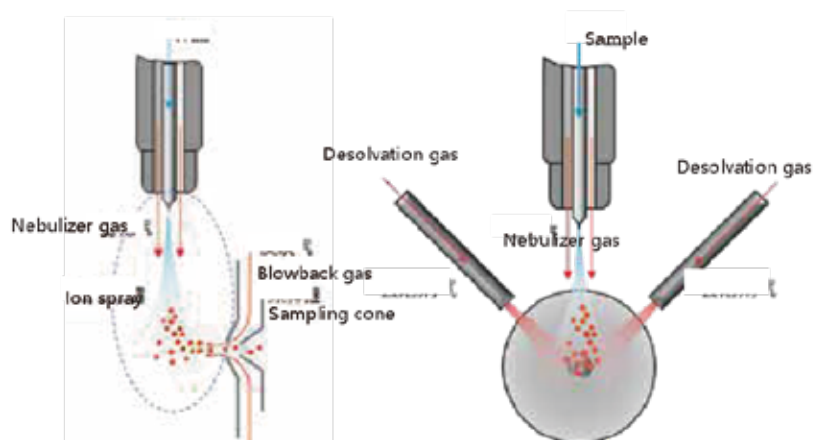

Anti-pollution vacuum interface

Gas curtain formed by back blowing of high temperature nitrogen flow Effective removal of neutral particles prevent large droplets from entering the vacuum area

Micro negative pressure in atomization chamber to discharge solvent droplets



Ultra trace signal detection Channel electronic multiplier the design of off axis to filter the noise of neutral particle

Innovative pulse detection technology can improve the signal-to-noise ratio effectively and obtain better analysis results.

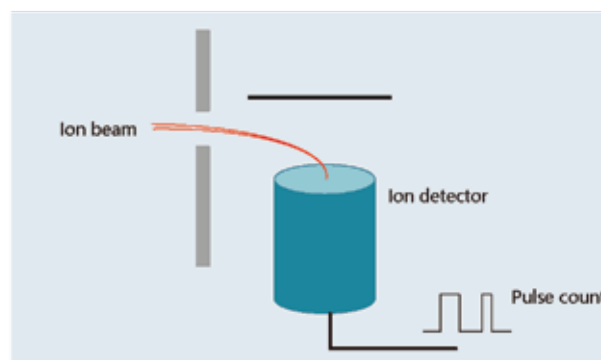

Vacuum system

Differential vacuum design to reduce ion transmission loss

At the same time, it also reduces the molecular pump load and improves the service life of the turbo molecular pump

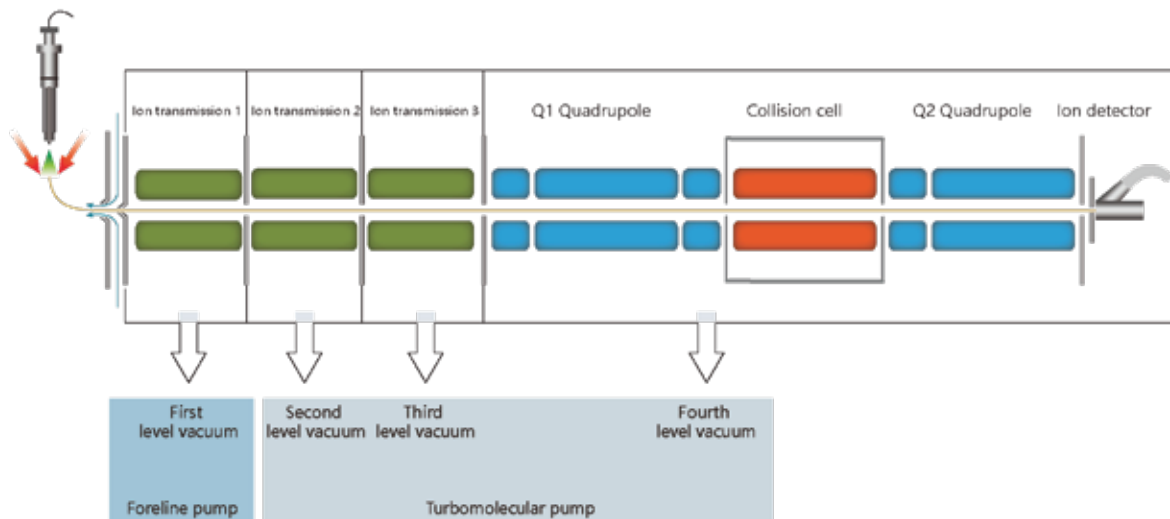

Excellent stability

1000 needles of continuous injection over 168 hours, peak area of 3 sulfonamides CV < 4%

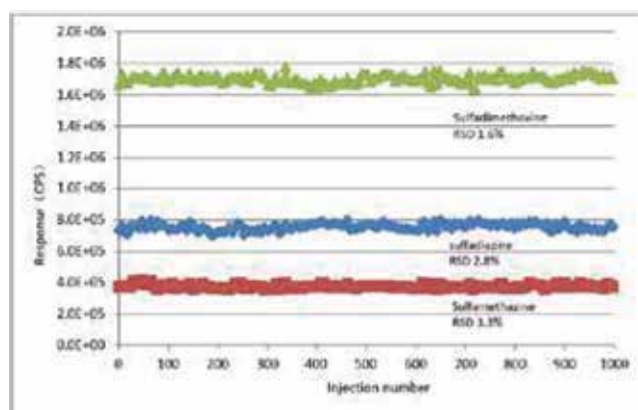

Powerful and friendly Mass Pandit analysis workstation

Mass Pandit workstation, a kind of new user experience, and there are no learning disabilities.

With rich intelligent kits to meet the application needs of different levels from experts to experimenters

Powerful high-throughput data batch analysis software makes analysts no longer stay at the side of the instrument

The built-in standard spectrum library contains thousands of compounds, and supports self-built spectrum library, which is convenient for users to build their own methods

Provide special solutions for industrial applications, and provide customized method packages for environmental monitoring, online analysis, etc.

Easy to use Easy-to-use control software The interface, with new user experience

Optimize the methods automatically to accelerate the development process of method.

Monitor the instrument status in real time to reduce the difficulty of diagnosis and maintenance

Intelligent parameter optimization

One-click automatic tuning and quality calibration to reduce the difficulty of users

Parameter adjustment tool tailored for advanced users to meet personalized experimental needs

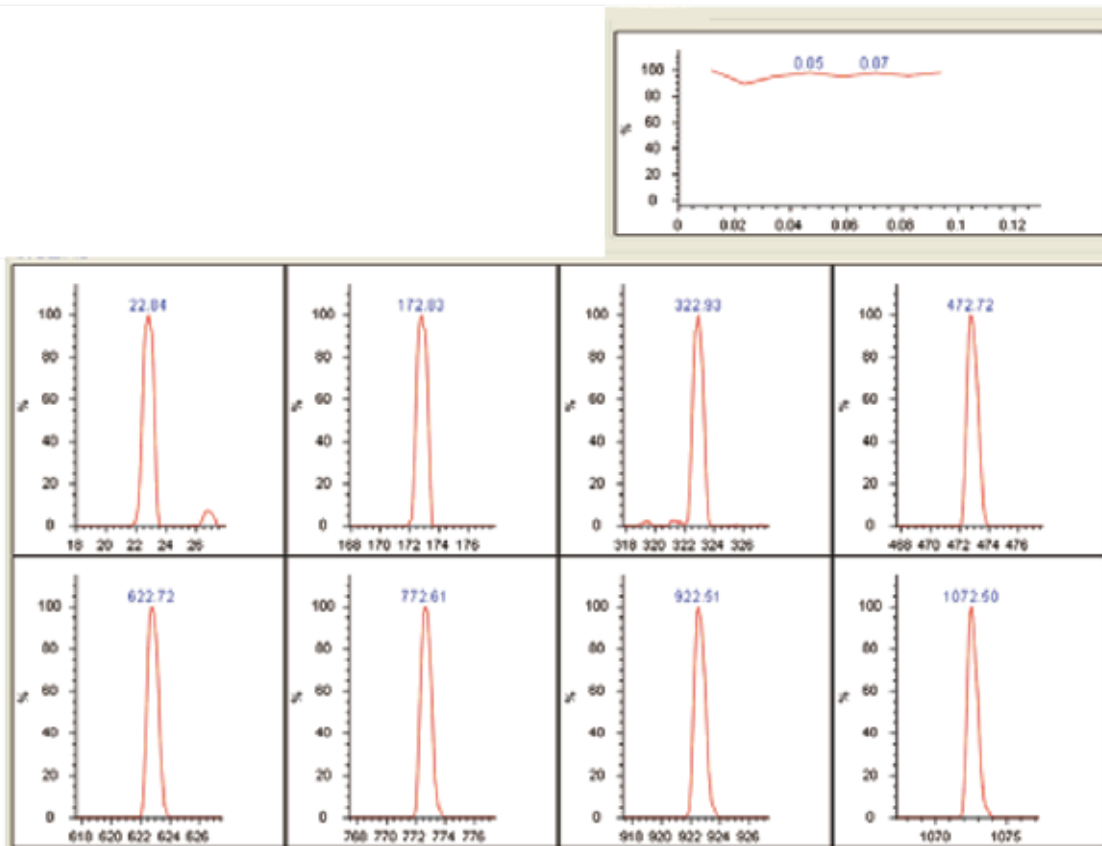

Customizable application analysis software

Customized special software for environmental protection, medical diagnosis, food safety, online analysis and other applications.

In-built compound library and analytical method library to provide analytical method support for compounds

Mark outliers automatically to speed up analysis

The setting of no parameter automatic integrator to reduce the tedious operation of manual integration

Analysis data statistics and trend displayed by chart are convenient and intuitive

Liquid chromatography system

Humanized design to improve user experience

Plunger rod self-cleaning (back wash) is equipped as standard to reduce the impact of buffer salt on the pump system and prolong the service life of the gasket

Online degasser (Degasser) is equipped as standard to reduce user's exhaust bubble operation and improve system operation stability.

Solvent switching valve (SSV, optional), which can quickly switch four mobile phases on the binary pump without manual switching of mobile phases



The system has small delay and realizes rapid gradient change

The gradient of mobile phase B (5% → 95%) changed rapidly within 2 min, and then balanced to the initial 5% B within 25s, reflecting the super performance of the infusion pump

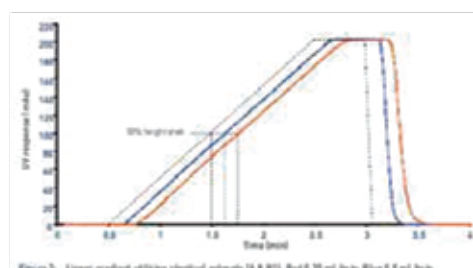

High gradient accuracy to ensure experiment repeatability

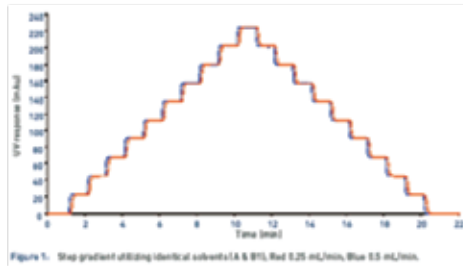

Figure 5. Step gradient of eluting identical solvents (A & B) at 0.25 mL/min (Red) and 0.50 mL/min (Blue).

Subrent composition accuracy (Bias, %)										
Flow (mL/min)	Composition (% B)									
	10	20	30	40	50	60	70	80	90	100
0.25	0.02	0.05	0.04	0.07	0.15	0.20	0.19	0.07	0.05	
	0.04	0.11	0.14	0.14	0.16	0.14	0.14	0.22	-0.01	
0.50	-0.02	-0.04	-0.03	-0.04	-0.02	-0.01	-0.03	0.18	0.23	
	0.00	0.04	0.04	0.04	0.05	0.03	-0.01	-0.01	-0.02	

Multifunctional injector to realize ultra-low temperature injection Matching multiple types of injection trays 48 position sample tray (2ml universal sample bottle) 96 position shallow hole plate / deep hole plate 384 bit micro-plate 10ml sample bottle

Ultra low temperature sample injection function (optional)

Truly realize the cooling injection at 4 °C, which is suitable for easily deteriorated samples such as biological samples



Unique needle washing design realizes zero residue of samples

The "needle inside needle" design of the combination of outer needle and inner needle truly realizes zero residues of samples

Programmable needle washing program, which can switch up to 6 kinds of needle washing solutions

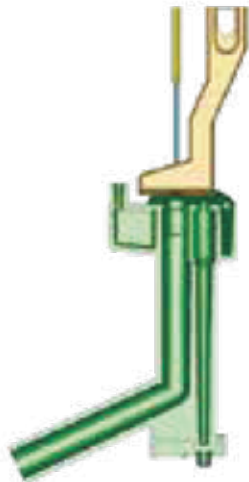

Reliable column oven

Temperature range: room temperature + 5 - 90 ° C, accuracy < 0.1

Multi-dimensional alarm protection to ensure the normal operation of the system
liquid leakage alarm Door opening alarm when heating Heating timeout protection Heating over temperature protection up to 6 different chromatographic columns can be switched through column switching valve to save time of method development.

Series products

LC-MS/MS 3521 is a new generation of LC-MS / MS, with excellent sensitivity and stability. It is suitable for a wide range of application fields such as environmental testing, medical testing, drug testing and food safety.

LC-MS/MS 3521 is equipped with Mass Pandit mass spectrometry workstation, including professional mass spectrometry control and quantitative analysis software. It contains thousands of compound standard libraries and rich application method libraries, which greatly reduces the operation the operation difficulty of mass spectrometry software system.

LC-MS/MS analysis system can be configured: ULC 500 HPLC or ULC 510 UPLC
AS 510 auto sampler
CH 520 column temperature box

Application case

1. Detection of sulfonamides in pork

The limit of quantitation is 2 orders of magnitude better than the detection limit of national standard GB / T 20759 - 2006, and meets the detection and application needs of 16 sulfonamides in meat.

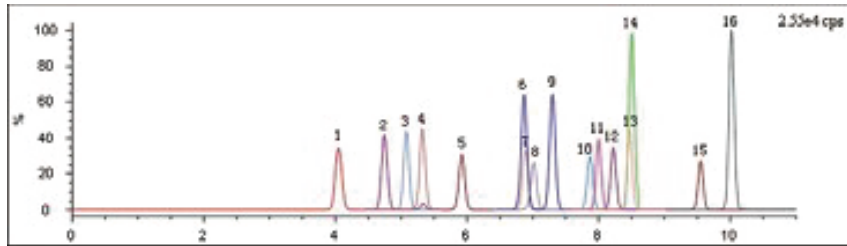

2. Detection of carbamate pesticides in water

It has a strong ability to analyze multicomponent pesticide residues in complex substrate of environmental water.

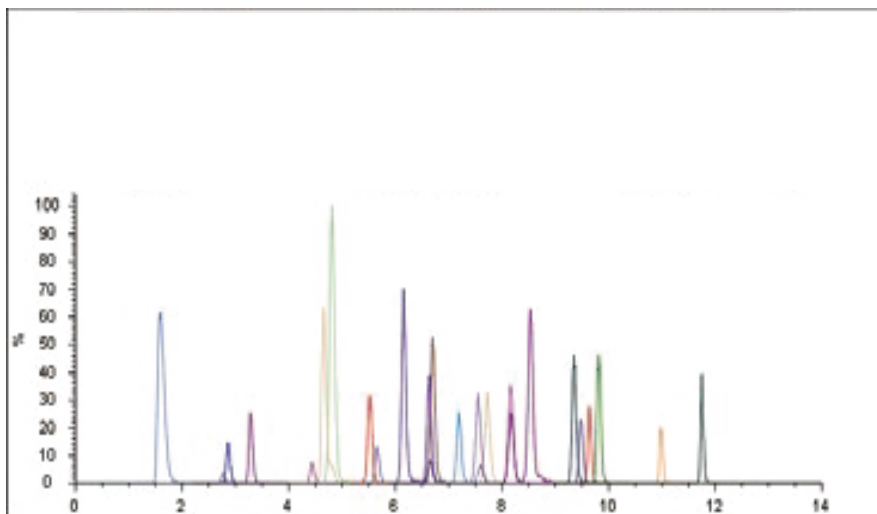

3 .Detection of perfluorinated compounds in environmental media

LC MS/MS was used to quantitatively evaluate the pollution level of per fluorinated compounds in environmental media in ordinary areas (city A) and production area (city B), so as to provide reference for environmental monitoring and treatment.

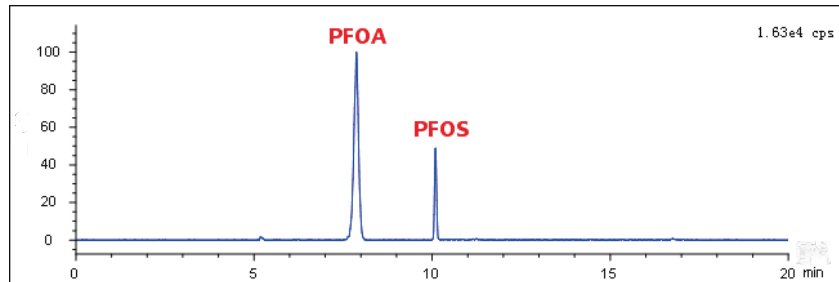

4.Screening of neonatal genetic metabolic diseases

More than 60 kinds of amino acids and acyl carnitine in neonatal blood were quantitatively analyzed by LC-MS/MS 3521. More than 30 kinds of genetic and metabolic diseases could be screened in only 2 minutes each time.

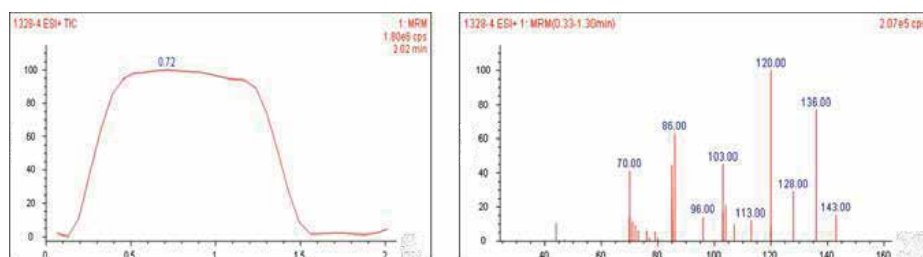

5.Determination of vitamin D in serum

The concentration of 25-hydroxy-vitamin D in serum was determined by LC-MS/MS3521 to evaluate the nutritional status of human vitamin D, which can meet the needs of clinical detection

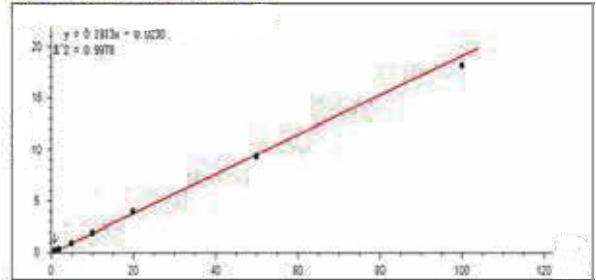
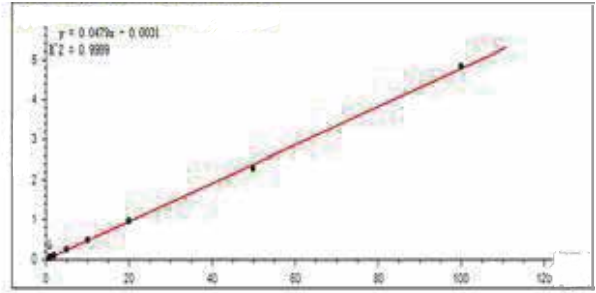
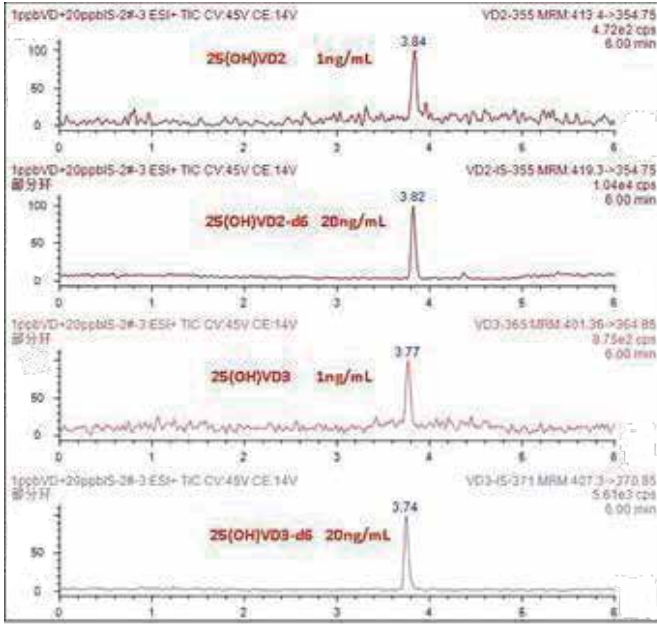

Technical Specification of Liquid Chromatograph - Triple Quadrupole Mass Spectrometer

1. Scope of application

LC-MS/MS 3521 Liquid chromatograph - triple quadrupole mass spectrometer, integrating the high separation efficiency of liquid chromatograph and the strong identification capability of mass spectrometer, has sufficient sensitivity and selectivity, good stability and strong anti-interference. Therefore, it is applicable to the qualitative and quantitative analysis on high sensitivity of trace pesticides and veterinary drugs in complex matrix.

2. Work environment

1) Work environment temperature: 18 -25 °C

2) Humidity in work environment: (20 ~ 60)% RH

3) Power supply: five sets of single-phase (220 ± 20) V AC, 10A, 50 Hz power supply

3. System technical specifications :

Configuration and performance indicators of liquid chromatograph

Ultra-high pressure gradient pump

Two solutions in A and B, or C and D, can be selected as the flowing phase of the system by switching the solvent selection valve. A vacuum degasser is equipped, with each pump degassing separately (A/B). 3.1 Flow range: 1-4,000 μ L/min in Maximum pressure: $\geq 18,850$ psi 3.1 .1 .5 Accuracy of flow rate: $\leq 1\%$ Precision of flow rate: $\leq 0.075\%$ RSD 3.1 .2 Automatic sample injector Three injection modes: full loop injection, partial loop injection and microliter pickup. Injection repeatability: Full loop injection $< 0.3\%$ RSD; partial loop injection $< 0.3\%$ RSD; microliter pickup $< 1.0\%$ RSD Cross contamination: $< 0.05\%$ Maximum sample capacity: 384 bits, and 96 bits for standard liquid injection. Column oven Temperature control range: Room temperature + 5 °C - 90 °C Temperature control mode: preheating of flowing phase + forced air circulation

Maximum column capacity: Six 250mm long chromatographic columns can be installed at the same time.

Requirements for configuration and performance indicators of mass spectrometry system

Ion source (spray ion source for standard configuration) Orthogonal vertical spray design is adopted, so that the system has strong anti-pollution capacity and low background noise.

Ion source gas supply: 1 loop of nitrogen for atomizing and 2 loops of nitrogen for desolvation. Specifically, the flow rate of nitrogen for atomizing is 0-2L/min, and that for desolvation is 0-15L/min. The maximum spray voltage is 6kV. The flow rate, voltage, and temperature can be set up and run under the software interface, to ensure the maximum ionization efficiency and resistance to matrix interference.

A special exhaust device is set in the ion source to prevent the back flow of gas in the closed ion source cavity, further to reduce the memory effect and pollution of the ion source, decrease the load of the mechanical pump, prolong the service time of the mechanical pump oil, maintain the test environment and ensure the health of the staff.

Vacuum interface and ion transmission system

High temperature blow back gas design: Nitrogen is used as the blow back gas, with a flow rate of 0-5L/min to further remove the solvent and reduce the introduction of neutral molecules.

Heating design of vacuum interface: It can be heated to 110°C at most to improve the anti-pollution capacity

Vacuum interface maintenance: simple cleaning and maintenance, without vacuum loading. The whole process of daily maintenance and installation can be easily completed in a few minutes.

Ion transmission system: 4-stage differential vacuum design is adopted, and multiple quadrupole transmission is used for accurate focusing of ions.

Mass analysis system

Mass analyzer: Triple quadrupole mass analyzer

Quadrupole: Made of high-precision pure Mo material, capable of ensuring the best mass axis stability.

Collision cell: Axial acceleration design is adopted, capable of effectively eliminating the interference of ion pair and ensuring the high-throughput analysis capability. Nitrogen (with purity $\geq 99.999\%$) is used as the collision gas and supplied in cylinder

Resolution: 0.4-2.0 amu (adjustable)

Mass stability: better than 0.1 amu/24 hours.

Scanning speed: $\geq 20,000$ amu/s

Number of MRM channels: 100 channels/s

Mass range m/z: 5-1,000 amu

Dynamic range: 6 orders of magnitude

Sensitivity: ESI+, MRM mode: 1 pg reserpine, injected on the column, with $S/N \geq 100,000:1$; ESI-, MRM mode: 1 pg chloramphenicol, injected on the column, with $S/N \geq 100,000:1$;

Scanning functions: Full scan, selected ion monitoring (SIM), product ion scan, precursor ion scan, neutral loss scan, multiple reaction monitoring (MRM), positive/negative ion switching scan, etc.

Multiplier technology, without any positive and negative ion discrimination effect, which has long service life, capable of ensuring the long-term data stability.

Pulse-counting detector, to ensure the data reproducibility of low limit of detection.

Positive/negative polarity switching time: ≤ 50 ms

Vacuum system: composed of a mechanical pump and a turbo molecular pump, with a differential pumping system formed between the ion transmission area and mass analysis area, functioning for automatic power-off protection

Workstation software

Basic features of software system: Windows XP or above operating system. The software can control the liquid chromatograph and mass spectrometer, with built-in data processing and report editing functions. Besides, the software can realize the function configuration and condition optimization of the instrument automatically, the automatic quantification, the mass spectrometry data analysis, and the establishment and retrieval of spectral database.

The system has the functions of automatic correction and instrument condition monitoring.

The LC-MS operation software can be installed on the personal computer, and used for the offline processing of sample analysis data and report generation.

Accessory system

Computer system

Brand computer with mainstream configuration, 4GB memory, 1TB hard disk.

AC stabilized power supply

15KVA, input voltage of 140v-300v, output voltage of 220 V \pm 1%.

Laser printer

6018L, black and white laser printer.

Nitrogen generator

The maximum flow is 24L/min and the maximum pressure is 116psi.

Mechanical pump

Pumping speed: 65m³/h, 220V power supply, 800W

HPLC Servicing, Validation, Trainings and Preventive Maintenance :

HPLC Servicing :HPLC Servicing : We have team of service engineers who can attend to any make of HPLC promptly @the most affordable cost.

Trainings :We also take up preventive Maintenance to reduce downtime of HPLC's Trainings.

AMC's/CMC :AMC's/CMC :We offer user training both in-House and at customer sites on HPLC principles, operations, trouble-shooting.

Validations :Validations :We have protocols for carrying out periodic Validations as per GLP/GMP/USFDA norms.

Instruments :Instruments :We offer instruments/Renting Services Modules like pumps,detector etc. on Rent.



About Analytical Technologies

Analytical Technologies is synonymous for offering technologies for doing analysis and is the Fastest Growing Global Brand having presence in at least 96 countries across the global. Analytical Technologies Limited is an ISO:9001 Certified Company engaged in Designing, Manufacturing, Marketing & providing Services for the Analytical, Chromatography, Spectroscopy, Bio Technology, Bio Medical, Clinical Diagnostics, Material Science & General Laboratory Instrumentation. Analytical Technologies, India has across the Country operations with at least 4 Regional Offices, 6 Branch Offices & Service Centers. Distributors & Channel partners worldwide.

Our Products & Technologies



UV/VIS
Spectro 2080+
Double Beam



Infra FTIR



Optima Gas
Chromatograph
3007

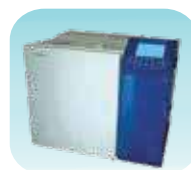

Optima Gas
Chromatograph
2979 Plus



Flash
Chromatograph



Atomic Absorption
Spectrophotometer



Liquid Partical
Counter



Optical Emission
Spectrophotometer



DSC/TGA



Semi Auto Bio
Chemistry Analyzer



HEMA 2062
Hematology
Analyzer



Micro Plate
Reader/Washer



URINOVA 2800
Urine Analyzer



Total Organic
Carbon 3800



Fully Automated
CLIA



NOVA-2100
Chemistry Analyzer



PCR/Gradient PCR/
RTPCR



TOC
Analyzer



Laser Particle
Size Analyzer



Ion Chromatograph



Water purification
system

Regulatory compliances



Corporate Social Responsibility

Analytical Foundation is a nonprofit organization (NGO) found for the purpose of:



Analytical Foundation

1. Research & Innovation Scientist's awards/QC Professional Award : Quality life is possible by innovation only and the innovation is possible by research only, hence ANALYTICAL FOUNDATION is committed to identify such personalities for their contributions across various field of Science and Technology and awarding them yearly. To participate for award, send us your details of research / testing / publication at Info@analyticalfoundation.org

2. Improving quality of life by offering YOGA Training courses, Work shops/Seminars etc.

3. ANALYTICAL FOUNDATION aims to DETOXYFY human minds,souls and body by means of yoga, Meditation, Ayurveda, Health Care, Awards, Media, Events, Camps etc.



HPLC Solutions MultipleLabs Analytical Bio-Med Analytical Distributors Analytical Foundation (Trust)

Corporate & Regd. Office:
Analytical House, # E67 & E68,
Ravi Park, Vasna Road, Baroda,
Gujarat 390 015. INDIA

T: +91 265 2253620
+91 265 2252839
+91 265 2252370
F: +91 265 2254395

E: info@hplctechnologies.com
info@multiplelabs.com
info@analyticalgroup.net

W. www.analyticalgroup.net
www.hplctechnologies.com
www.multiplelabs.com

Sales & Support Offices:
across the country :
Distributors & Channel
partners World Wide